

ASSASSIN Building Instructions by CRASHTESTHOBBY.COM

The Assassin is the toughest plane on the planet!!! The Assassin can take more abuse and keep on flying better than any other plane we have seen. It is cut from solid EPP foam that doesn't crush. It has EPP elevons that don't split. It uses a shock cord that spreads out the forces of impact. It has bidirectional reinforced Extreme Tape hinges and laminate to make it able to hit a brick wall at full speed and survive while protecting the battery and radio. The plane is designed to use low cost off the shelf motors, ESCs, servos and batteries. You need one of these!!!! Your club needs a bunch of these. It's time to fly without worrying about breaking your plane. Fins are optional. Don't cut tip angles if you want to use the fins. (see pictures #1 and #9 below.)

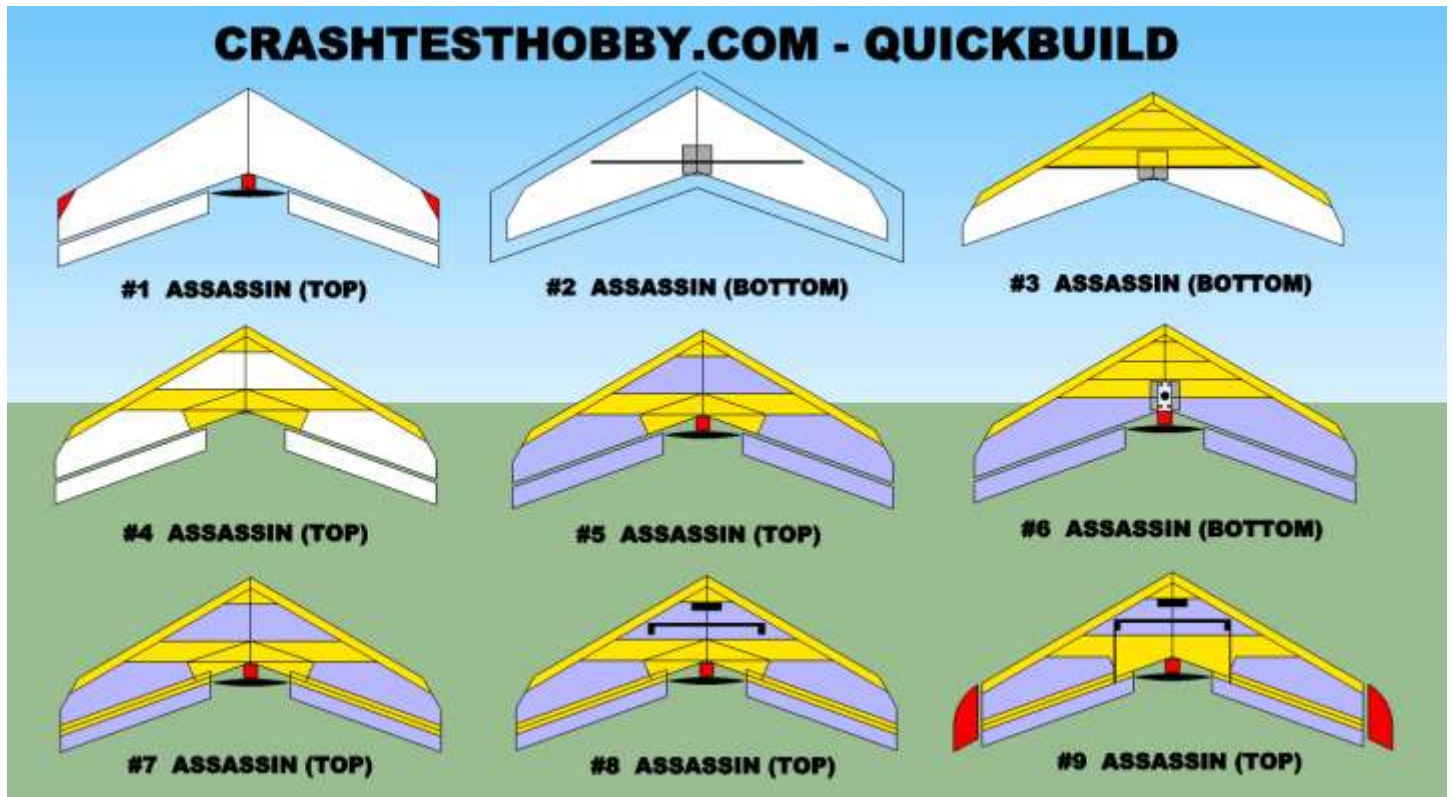

ASSASSIN QUICK BUILD INSTRUCTIONS

Go watch our building videos to see how we build at <http://www.crashtesthobby.com/assassin-building-videos.html>

1. Glue cores together. Cut elevons to length. Optional finless design - Cut wingtip stabilizer angles 2" X 2" (shown red in photo #1)
 2. Cut spar slit 6.5" back from nose on the bottom of the wing. Glue the spar in slit. Install the shock cord in a slit around perimeter of wing that is cut with a new razorblade. Glue Formica mount on the bottom in center of wing.
 3. On bottom of wing put 2" strips of Extreme tape from spar forward. Wrap 2" E-Tape around leading edge of wing.
 4. On top of wing put 2" E-tape from 4" forward. Tape across center of wing over spar and reinforce core between elevons.
 5. Put 2 layers of laminate (blue) on elevons. Put one layer of laminate on top and bottom of wing over foam and tape.
 6. Mount motor on metal motor mount. Screw motor mount on Formica plate
 7. Make elevon hinges with 1" wide E-Tape top and bottom of wing. Iron 2" wide laminate strips over tape to protect from UV light.
 8. Cut out battery hole with battery back 2.5" with battery on edge. Cut radio slot 4.5" back with servo on each end of 10" slot. Servos stand upright deep in foam with arm near surface of wing. ESC and receiver sit on edge in slot.
 9. Install radio, horns, and rods (and fins) Have servo arms to outside edge of slot. Pushrod near center of servo arm and at tip of elevon control horn for maximum leverage. Install pushrod guides.
 10. CG is 6.5" back. Elevon throws no more than 3/8" Trim both elevons up 1/4" (reflex) make Velcro tie down for battery and radio.
- *** To build an ultra light plane replace all E-Tape with 2" laminate strips and use lighter battery and radio. ***

Specifications

- Center of gravity is back 6.5" (16.5 cm) from nose of plane
- Spar is back 6.5" (17 cm) from nose of plane which helps to check the CG location
- Start with no more than elevon throws at 3/8" (1 cm) up and down, more is fun later.
- Target all up weight 17-20 oz (480-600 gm)
- 2812-1534 motor with 25+ amp ESC and MG90 servos
- 1000-1800 mah 3S lipo batteries



EQUIPMENT NEEDED

1. Low-temperature hot glue gun and low-temp rated glue
2. or Gorilla Glue (preferably white), or "Goop" brand glue
3. Metal straight edge
4. Soldering iron
5. Pliers
6. Pen
7. Adjustable razor blade
8. Philips head screwdriver
9. Electric drill and bits
10. Iron for applying laminate (hobby iron is preferable, but clothing iron may be used)
11. Velcro strips



WING PREPARATION – the Assassin flies well with or without fins. We found ourselves frequently reattaching the fins on the wingtips of our combat planes, so we got rid of the fins. Our angled tips on the Assassin's fat airfoil create stabilizing drag like a fin and make it incredibly stable at speed. Many flyers are not doing combat and like the more solid tracking and improved slower flight performance with fins. Here are instructions for both. It's your choice.

1. Rub the EPP foam surfaces with another piece of EPP foam to get the melted fibers off. Use your fingernail to pick off any stubborn fibers. You can also use a disposable razor to shave the EPP foam to get the fibers off.
2. Glue the wing halves together with low-temperature hot glue, Goop, or Shoe Goo.
3. **Skip to SPAR instructions if you are building your Assassin with fins. (The Widowmaker needs fins.)**
4. To build the Assassin without fins, you will need to cut a flat-faced angle onto the front of the tips. This gives some resistance on either side of the wing to stabilize the plane and prevent unwanted yaw during flight.
5. To cut angles in the tips, for flying without fins, use your ruler to measure from the leading corner of one wingtip, 2" (5 cm) in along the leading edge, towards the nose. Place a mark at that point with your pen.
6. Also measure from the leading corner of the wingtip, back along the outside edge of the wing, and place a mark at 2" (5 cm).
7. Lay your straight edge from the 2" mark on the leading edge, to the 2" mark on the side of the wing. Use a sharp razor blade to cut this corner off of the wingtip. Do not round the corners. The flat surface is part of the design.
8. Repeat on other wingtip. Make sure both wing tips are exactly the same.



SPAR – There is 1 flat carbon spar included in the kit, which will be installed across the width of the wing

9. On the bottom of the wing, lay a straight edge along the center of the wing, and place a mark at 6.5" (17.cm) back from the nose
10. From the 6.5" mark, use a square to measure out 10" to either side (20 inches total). Mark the 10" point with your pen.
11. Use your straight edge and a **new** sharp razor blade to cut a slit 1/2" (1 cm) deep enough for the flat carbon spar.
12. You can work baking soda into the slit to act as a catalyst for the CA glue for a quicker set of the glue.
13. Baking soda is in the basing syringe (red bulb) you see in the attached picture.
14. Sand the spar lightly to take the shine off it. Press the spar into the slit. Glue it in with CA glue.



SHOCK CORD

15. The weakest point of a flying wing is the space between the elevons on the trailing edge. In a head-on impact the weight of the wingtips tears the wing in half from the back forward. The Shock Cord ties the trailing edge of the wing together to prevent this damage from occurring. The Shock Cord can be glued in with baking soda and CA glue or gorilla glue and water.
16. Using a razor blade, cut a 3/8" (0.7cm) deep slit around the entire perimeter (along the edge) of the wing.



17. Work a little baking soda in the slot and put some baking soda on the cord first to speed up curing later.
18. **Make sure you have adequate ventilation and beware of the fumes. CA glue and baking soda have a fast reaction.**
19. Insert the shock cord with the center of the cord at the tail, and the loose ends at the nose. Use your finger or a Philips Head screwdriver to push the cord into the slot. Keep tension on the cord as you work your way around the wing, so that it is snug, and all slack moves towards the loose ends at the nose. Tie the loose ends of the cord together at the nose, so that the knot tucks into the slot. Cut off excess cord, so that no cord is showing.
20. Using CA glue work your way around the wing slowly squeezing CA glue into the slit. Beware of fumes and extra glue.



FORMICA PLATE – Formica is thinner and stronger than plywood.

21. Place the Formica plates on the **bottom** of the wing, white side out, at the center of the trailing edge. The plate should hang over the trailing edge at least enough that the stainless steel motor mount won't be resting on the foam.
22. Make sure that the spar is not under the large hole in the motor mount if you are going to add a bomb drop.
23. Center the plate, and mark with a pen on the EPP foam where the corners are.
24. Put low temperature hot glue **on the foam** (not the plate) where the plate will be, and quickly but accurately affix the plate. If you apply the glue to the plate it will cool and set before you can get it in position on the wing.
25. Do not attach the stainless steel motor mount at this point. That will be done after laminating the wing.

SCOTCH EXTREME TAPE – available from many office supply stores and Amazon

26. Scotch Extreme Tape© will stick to EPP without a spray adhesive. It is lighter than many other reinforced tapes. It can hold up to 150 lbs of weight per inch. It is available at many office supply, hardware, and postage stores. Extreme tape needs to be covered with laminate or it will yellow and dry, and come off in UV sunlight. The tape needs to be tight for maximum strength.
27. Look at the taping pattern for the top and bottom of the Assassin shown in the quick build instructions at the first of the instructions. This is reinforced for combat and adds about 2 oz to the plane.
28. The main points that benefit from the reinforced tape are the leading edge and the hinge line.
29. Assassins can be built with 2" tape, lighter with 1" tape and ultra light with laminate strips instead of tape.
30. When 1" wide strips are needed, lay the strip on a piece of glass or a cutting table, then use a straight edge and sharp razor blade to split the 2" strip into two 1" strips.
31. The first set of tape will form an "X" over the Formica plate on the bottom of the wing and directly above it on the top of the wing to help the shock cord. The elevons will add more strength out farther on the wing when they are installed.
32. For additional strength in the nose of the plane, put strips of Extreme tape side to side that go from the spar forward on the bottom of the plane. Be careful not to add too much weight. (not shown in pictures)
33. Lay a 2" wide strip along the leading edge, the entire length of the wing, folding equally over the top and bottom of the wing, and covering the ends of the strips you laid over each spar.

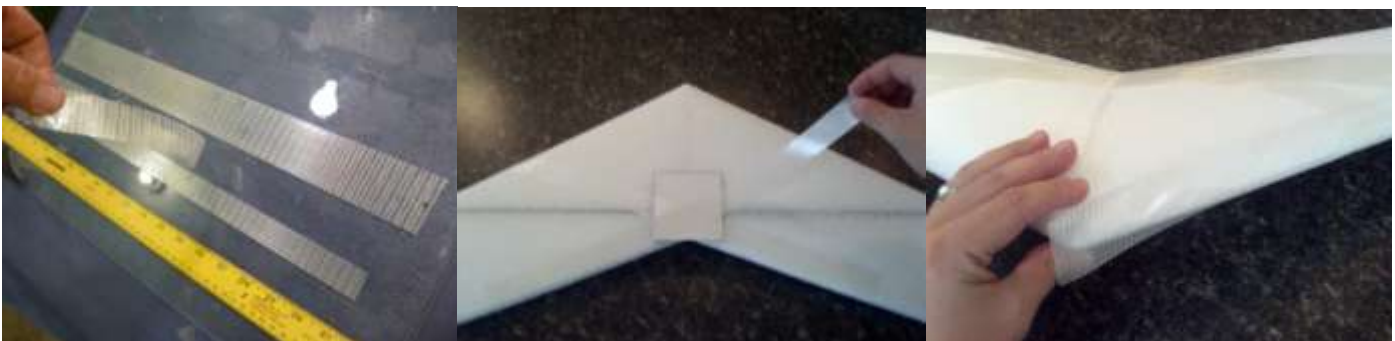

ELEVONS - Two elevons move up and down like an elevator and opposite for aileron function or roll.

34. EPP elevons will feel floppy until they are laminated and hinged to the wing. This flexibility keeps them from breaking in an impact. They are more durable than balsa elevons. Before cutting your elevons, you must determine which size of a propeller you will be using so you leave space for clearance.
35. **The elevons have a top and bottom. Make sure the point is at the top of the elevon is up and that you make a right and left elevon.**
36. Lay your elevons next to the trailing edge of the wing, thick side towards the wing, with the point of the slanted cut at the top of the wing.
37. Cut the elevons to length to get the prop clearance. Hold your motor/prop assembly on the Formica plate to simulate how far the ends of your prop will reach, (e.g. a 7" propeller will reach 3.5" from the center on either side).
38. Making sure the elevon reaches the wingtip, mark where the elevon must be cut to allow the prop at least ½" (1 cm) of clearance on either side.
39. Cut the trailing corner of the elevon nearest the center of the wing, with the cut being parallel to the center line of the wing.
40. Repeat on the other elevon and make sure they are the same size and that you have cut a right and left elevon.



LAMINATE – the kit includes clear laminate that has UV protection to protect the Extreme Tape and foam.

The laminate included in this kit adds strength and protects the foam, tape, and plane from UV light, dirt, and water. This laminate is stronger than most iron-on coverings, and easier to work with. It is crystal clear and easily decorated with colored packing tape, holographic tape, or other iron-on coatings. LED lights shine brightly through the laminate for night flying. The rough side of the laminate goes against the foam. The EPP foam can't handle as much heat as the laminate, so make sure your iron isn't so hot that it will change the shape of the foam.

41. The temperature of the iron should be hot enough to activate the adhesive in the laminate but cool enough it won't change the shape of the foam. Start cooler and practice on a scrap and iron it to the box to get the feel of ironing the laminate.

LAMINATING THE WING – Put one layer of laminate over the entire surface of the wing.

42. Cut lengths of laminate that will cover each wing. Make sure the pieces will completely overlap (by about 2" (5cm)) in the center of the wing. Fold the laminate over the wing with the rough side of the laminate towards the foam, making sure it covers the entire top and bottom, overlapping the center
43. Iron the laminate down by working from the middle to the edges, using short strokes to keep wrinkles out as much as possible. Laminate directly over the Formica plates, and make sure to wrap around and seal the edges of the wing. Repeat on other side of the wing.



LAMINATING THE ELEVONS - two layers of laminate on the elevons make them as stiff as balsa.

44. Place one of the elevons under one edge of the laminate, so that the rough side of the laminate is facing the EPP foam.
45. Wrap the laminate end up over the elevon and make sure the elevon is straight before ironing.
46. Use your iron to stick the laminate to the foam. Begin at the center and work your way outward to avoid wrinkles.
47. Roll the elevon as you continue to iron keeping the laminate tight and ironing as you go. Keep the elevon straight.
48. Fold the laminate over and continue ironing until the elevon is completely covered with two layers of laminate.
49. Cut the extra laminate on the ends of the elevon to fold over neatly. Iron the laminate around the ends of the elevon. Repeat process with other elevon.
50. Make sure that the elevon turns out flat, after ironing. The heat can warp the foam a bit. If needed, re-heat and straighten the elevon, then hold it flat while it cools.



HINGING THE ELEVONS – The hinge is made from a 1" (2.5cm) wide piece of Extreme Tape covered with a 2" (5cm) wide piece of laminate.

51. Cut a piece of Extreme Tape into two 1" (2.5cm) wide strips, the length of the elevon
52. Position the laminated elevon next to the trailing edge of the wing, leaving a 1/16" (2mm) gap between the two pieces. Attach the elevon to the wing with one 1" (2.5cm) strip of Extreme Tape, on the top first.



53. Fold the elevon up and over, so it rests upside-down on the wing. Use the other 1" (2.5cm) strip of Extreme Tape to cover the hinge line.
54. The laminate hinges will fail in a few months if you don't put a laminate layer over them to shield the tape from UV rays.
55. Cut 2" (5cm)-wide strips of laminate the length of the elevon.
56. Cover the 1" (2.5cm) strips of E-tape you just placed with the 2" wide laminate strips and iron the laminate in place.
57. Make sure, as you iron, that the elevons end up flat and flush with the wing, not bending up in places. If they seem to be pulled in places, reheat the area with the iron, and lay an object over the elevon to keep it flat as the laminate cools.
58. Repeat on other elevon.



The basic schematic for the set up and installation of the radio gear and battery can be found at the end of the instructions. Servos plug into the aileron and elevator and are mixed to elevons on most radios. Consult your manual for specific programming with your radio.

MOTOR – We recommend the 2812-1534kv motor with a 25A ESC and a 3S 1000-1800 lipo battery.

59. We recommend 3mm bolts with nylon lock nuts or lock washers or equivalent to attach the motor to the stainless steel motor mount. (With the recommended 2812 motor, you can just screw on the red base.)
60. With the wing upside-down, place the motor mount on the Formica plate, and mark where the holes will be drilled.
61. Drill small pilot holes through the Formica plates and plane.
62. Do not drill into the carbon spar.
63. Make sure you will have prop clearance.
64. Screw the bracket to the Formica plate using #6 x 1/2 " metal screws, being careful not to over-tighten and crack the Formica.
65. You can leave the motor mounted to the bracket to properly measure the Center of Gravity later, but remove the prop for safety purposes.



SERVOS, BATTERY, ESC, AND RECEIVER – CENTER OF GRAVITY IS 6.5" BACK FROM THE NOSE

66. Install the battery is stood on its edge with a side facing forward back 2.5" (6.5 cm) from the nose of the plane.
67. Cut a single slot with a soldering iron 4.5" (11 cm) back and 10" (25.5cm) wide deep enough for the ESC and receiver to sit on their edge and the servos will stand upright with the servo arms on top at the ends of the slot with the servo arms toward the wingtips.
68. Put the arms of the servos to the outside edge of the slot to increase the distance between the horns on the elevons.
69. There are some flyers that prefer to cut individual holes for each of the radio parts. This helps to lengthen the motor wires if your ESC came with too short of motor wires. As long as the CG is right this works too.
70. On the bottom of the plane, measure for your CG 6.5" (16.5 cm) back from the nose, along the center line, and place a mark at that point. Your spar may be a good marker for finding and checking your center of gravity.
71. Use your square to mark points towards the edges of the wing, directly out from the 6.5" (16.5 cm) mark. Place push-pins or thumbtacks into those points so you will have a reference point as you balance your plane.



PUSH RODS AND SERVO HORNS

72. Put your push rods on the outside of the servo arms to get the maximum width. This allows you to place your push rod slightly further out the elevon, reducing the force required to move the entire elevon, and reducing any chance of twist in the elevon. You will want to use the hole closest to the servo.
73. Use the push rod to measure directly back from the hole in the servo arm, and place a mark on the front edge of the elevon. Depending on your servo, you may need to use a small drill bit to widen the hole in the servo arm, so that the rod fits through.



74. Use a sharp blade and cut a slit completely through the elevon where you want the horn. The mark you made in the previous step should be the *inside edge* of that slot, not the center to allow enough room for the EZ Connector on the servo horn.
75. Remove the extra tab that comes attached on the back of the servo horns.
76. Push the servo horns up through the bottom of the elevon so that the base is flat against the bottom of the elevon. Use hot glue along the base of the servo horn, and down through the melted slot, around the horn, to keep horn in place. As the hot glue dries, make sure the horn is facing straight forward. Your horns should point towards the servos, and the front of the horn should be directly over the elevon's hinge.



77. Attach the EZ Connectors to the control horns with a pair of pliers to the top hole in the control horn.
78. Remove the servo arms, slide the push rod through the hole in the servo arm. Place the end of the push rod through the EZ Connector, then set the servo arm back on the servo.
79. Mark a spot on the wing about halfway between the servo and the elevon, directly underneath the push rod.
80. Remove the push rod, and use your soldering iron to melt a hole at the mark you just made. This hole should be wide enough and deep enough that the push rod guide (the metal staple included in the kit) can sit in it, and extend just over the push rod.

81. Fill the hole with hot glue, and set the push rod guide (staple) in place. Hold it there while the glue dries. The staple keeps the push rod from flexing to the sides/up and down to keep the rod more stable.
82. Permanently attaching the push rods from servo arm to servo horn is best done later. This allows you to properly set the sub trim once all electronics are installed. It also keeps the rods out of the way as you finish the build.



BATTERY BAY – VELCRO RETENTION STRAPS

83. To hold the battery in place during flight, you can install Velcro strap. A simple way to do this is to cut a slit through the bottom front of the battery hole and one through the bottom in the middle of the slot that contains the radio and then feed the Velcro through and fasten it on the top of the wing. The Velcro over the wires will help hold the receiver and ESC in place along with securing the battery. See photo above.

PUSH RODS & ELECTRONICS TESTING

84. You will need elevon, delta or programmable mixing to mix the aileron and elevator channels to fly a plane with elevons.
85. Consult your radio manual for help if needed. On the Spektrum DX6i you may want to do manual mixing as described on our web site.
86. Remove the servo arms from the servos. Connect all electronics, including a battery, but for safety purposes, make sure you do not have prop attached to your motor at this point. Turn on your transmitter(tx) and allow the servo gears to “center” themselves.
87. Slide the push rod through the closest hole to the servo in the servo arm (still unattached to the servo), then slide the end of the push rod through the guide, and into the EZ Connector on the elevon. Then re-attach the servo arm to the servo so that the arm is perpendicular to the push rod.



88. With the EZ Connectors still loose, center the Subtrim function on your transmitter then put the servo arms perpendicular to the push rod.
89. Let the EZ Connector slide over the push rod as you lift your elevon so that the angle of the top of the elevon is parallel to the bottom of the wing. This is an approximate angle and may need to be adjusted during test flights depending on CG and weight. This is called **REFLEX** and is used on all flying wings and deltas.
90. Once in place, tighten the set screw on the EZ connector, and use snips to trim off excess push rod.
91. Repeat on other elevon and set it at the same angle.
92. Set the wing on a flat surface, and hold a ruler vertically next to the trailing edge of each elevon. Use your tx to set the throw (range of movement) on the elevons to 3/8” (1cm) up and 3/8” down. Make sure your stick movement translates to the proper up/down on your elevons:

STICK UP	Both elevons down	NOSE DOWN
STICK DOWN	Both elevons up	NOSE UP
STICK LEFT	Left elevon up / Right elevon down	ROLL LEFT
STICK RIGHT	Right elevon up / Left elevon down	ROLL RIGHT

ELECTRONICS COVERING, DECALS, & FINS

93. After testing all electronics, cover your receiver, ESC, and the slots you buried wires in, with clear tape and/or laminate to keep the radio from ejecting in an accident. The ESC gets hot and needs ventilation. The receiver and wires do not.
94. Add any other decals as you wish, but be careful not to add so much that it changes the Center of Gravity. *The lighter, the better!*
95. If you are using fins, hold the fins in place against the ends of each wing, and make a 1" (2.5cm) mark in the center of the fin, where it meets the top of the wing, then use your razor blade to cut out that 1" (2.5cm) section in the fin.
96. Shape the nose and top of the fin as desired.



97. Use Goop (or Shoe Goo) to glue the fins to the ends of the wings, with the slit just above the top of the wing.
98. Place a 2" (5cm) wide strip of Extreme Tape along the entire bottom of the fin, wrapping around to the bottom of the wing. Allow the glue to dry.
99. Cut a 1" (2.5cm) wide strip of Extreme Tape and feed it through the slit in the fin, so that the tape attaches to both the top and bottom of the wing, around the bottom portion of the fin.
100. Install prop with numbers facing the plane (if prop is installed backwards, it will not give you the necessary power).
101. Test the throttle and make sure the motor is turning in the correct direction. If not, unplug two of the three connectors between the motor and the ESC and reverse them. Try again.
102. Check your CG, the throw on the elevons, your linkages and reflex (slight up trim on the elevons) before launching.
103. It's always a good idea to have someone else double check your work. Field test and range check your equipment, then launch, trim, and enjoy!

LAUNCHING

104. **Launching from the tip is an art form and hard for many new flyers.** In the videos you see us launch our flying wings holding the plane by a wingtip while swinging it forward. We are actually setting the plane on the air without Frisbee spinning the plane. If you spin the plane at all the outside wing will have more lift because it is moving faster and the plane will roll the opposite direction and hit the ground. If you have any trouble, launch from the center of the plane with fingers on each side of the motor and toss the plane at the horizon. Don't throttle up till your hand is clear of the propeller.

The most common problems we see are:

105. **CG too far back.** Flying wings will not fly tail heavy. A good sign you are tail heavy is you can't control the plane or the plane won't stay trimmed. When you try to loop the plane will roll over. Add weight to the nose to see if the problems resolve. It is not uncommon to need an extra oz or two of lead depending on how light you build.
106. **Too much movement in the elevons** so the plane stalls on launch as you pull up on the elevator. Our planes have huge elevons to decrease drag so they don't need as much movement in the elevons as planes with small elevons. This is a very common problem!!!! May be combined or confused with tail heavy airplane symptoms.
107. **Loose servos in the foam, linkages and push rods that flex, and poor leverage with push rods not installed per plans, elevons are too soft and twisting.**

Setting up a radio for a flying wing and DX6i programming.

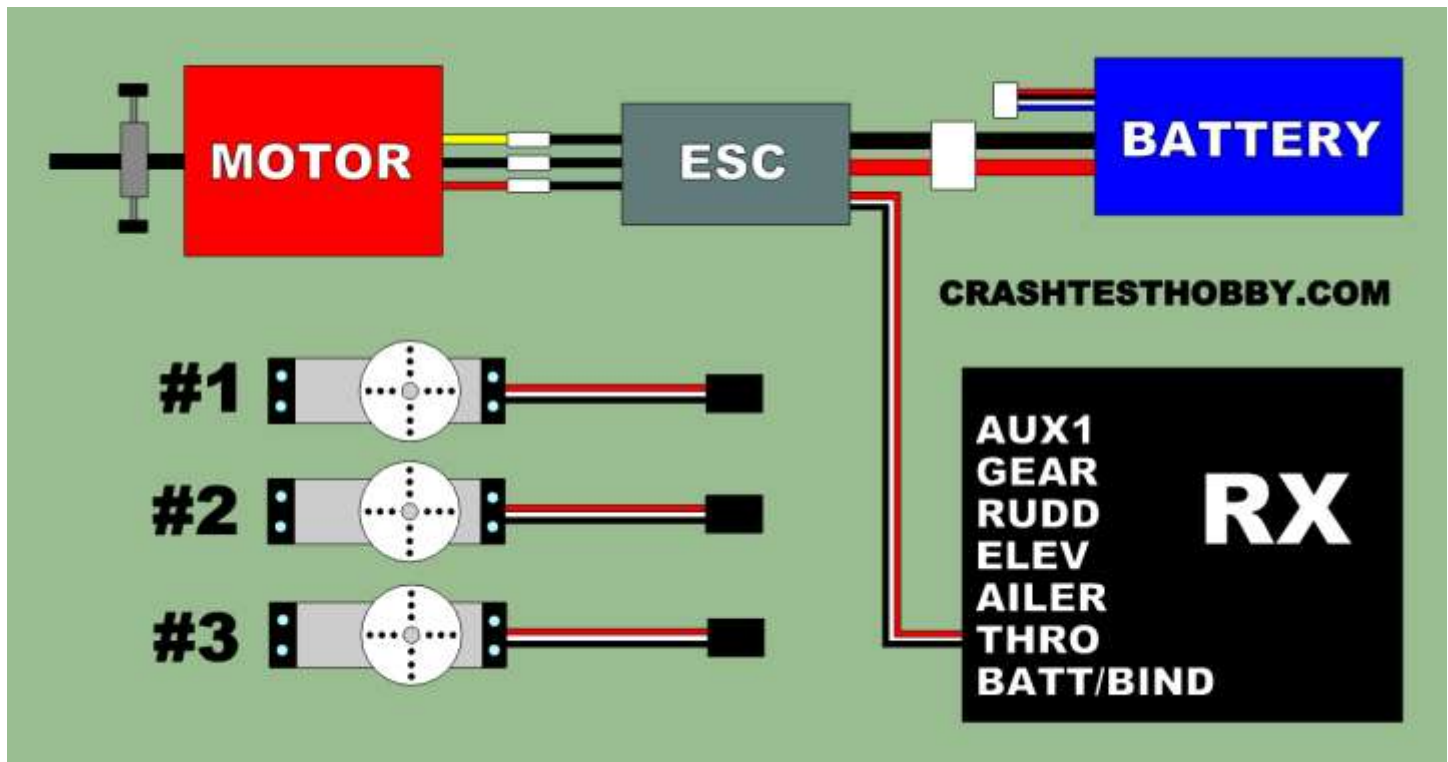

Connecting your battery to the ESC (electronic speed control).

- Look at the battery plugs that come on your batteries from the factory.
- There are several different plugs being offered.
- You won't have to change the plug on the battery if you match the plug with the plug you put on your ESC.
- Make sure your battery plugs can only be plugged together in only one way to protect the ESC.
- Frequently power wires get crossed during assembly. Make sure you solder the plug so the red wire from the battery only goes to the red wire plug on the ESC and the black wire to black wire.
- If these wires are switched, even for a second, the ESC will be destroyed and have to be replaced. This is not a defective part but the fault of the person assembling the electronics.

Connecting the ESC to the motor.

- The motor has three wires that connect to the ESC. You can plug these wires in any order.
- If the motor runs backwards trade any two wires and the motor will reverse direction.
- Make sure you heat shrink the connectors so they can't short out.
- If these wires touch and short out, while the motor is running, it will burn out the ESC.
- This is also not a defective product but the fault of the builder doing the assembly.
- There is no need for a reverse prop because it is so easy to change the direction the motor turns.

Connecting the ESC to the RX (receiver).

- The three strand wire with a plug on the ESC, plugs into the throttle plug on the RX (receiver).
- Look at the receiver for clues to which way the plug is inserted. Usually the black wire is to the back.
- Polarity is important. The ESC won't work if plugged in backwards but this does not harm "most" receivers.

Binding the 2.4G RX (receiver) to the 2.4G TX (transmitter) 72 meg transmitters do not have to be bound

- Consult your radio manual for 2.4G binding process for your radio.
- For most radios:**
- Plug a binding plug in the battery/bind plug on the receiver.
- Attach the battery and ESC to the receiver. An LED light should be blinking on RX.
- If your Tx can do more than one model set the Tx to the model location where you want to bind the RX.
- Turn the transmitter off and hold the binding switch on the transmitter while turning it back on.
- LED light on receiver will flash for a few flashes and then stay on and stop flashing or go out depending on the brand.
- Transmitter is bound to the receiver. Servos should respond when you move the sticks on the transmitter.
- Pull the binding plug out of the RX before unplugging the battery or you will have to bind again.

Connecting the Servos to the RX (receiver).

- Servos also have polarity and can only be plugged in one way and work.

- b) The servo plug will be inserted in with the dark wire to the back on most receivers.
- c) Choose the function you want the servo to do and plug that servo into that plug on the receiver.
- d) The servo may not turn the direction you want so you either need to flip a reversing switch on the transmitter or put the push rod on the other side of the servo.

Flying Wing Set up

- a) Flying wings use a mixing function which mixes two channels so that two servos will share the function of two different commands.
- b) Find out which two functions are mixed in your radio manual for elevons, delta or V-tail mixing.
- c) Most elevons are mixed with the elevator and aileron servos so in a flying wing you should plug the servos in to these plugs in the receiver.
- d) Check that your radio is working before turning on the mixing on your transmitter.
- e) Both servos should move with the up/down transmitter command and also with the right/left command.
- f) Both servos should be moved only by the right stick on the transmitter. (in USA)
- g) Some radios have other options. Some radios let you program which servos will be mixed.
- h) We have specific instructions for programming the Spektrum DX6i radio on our web site under "Instructions".

There are 8 different possible set-up for servo plugs and reversing switches and only one will work.

- a) Do a bench test to make sure all parts of your radio are working.
- b) Plug your servos in to the receiver after installing them in your plane in a way that you think will make it work.
- c) Test the movement and see if it goes in the right direction.
- d) If they aren't moving in the right direction, try different combinations of reversing the plugs in the receiver and flipping the reversing switches on your TX (transmitter) for the aileron/elevator servos until they work properly.
- e) Remember there are 8 different possibilities of ways they can be plugged and reversing switches set so it can be confusing at times.
- f) Your flight surfaces should move as follows when you move the right stick on the transmitter.

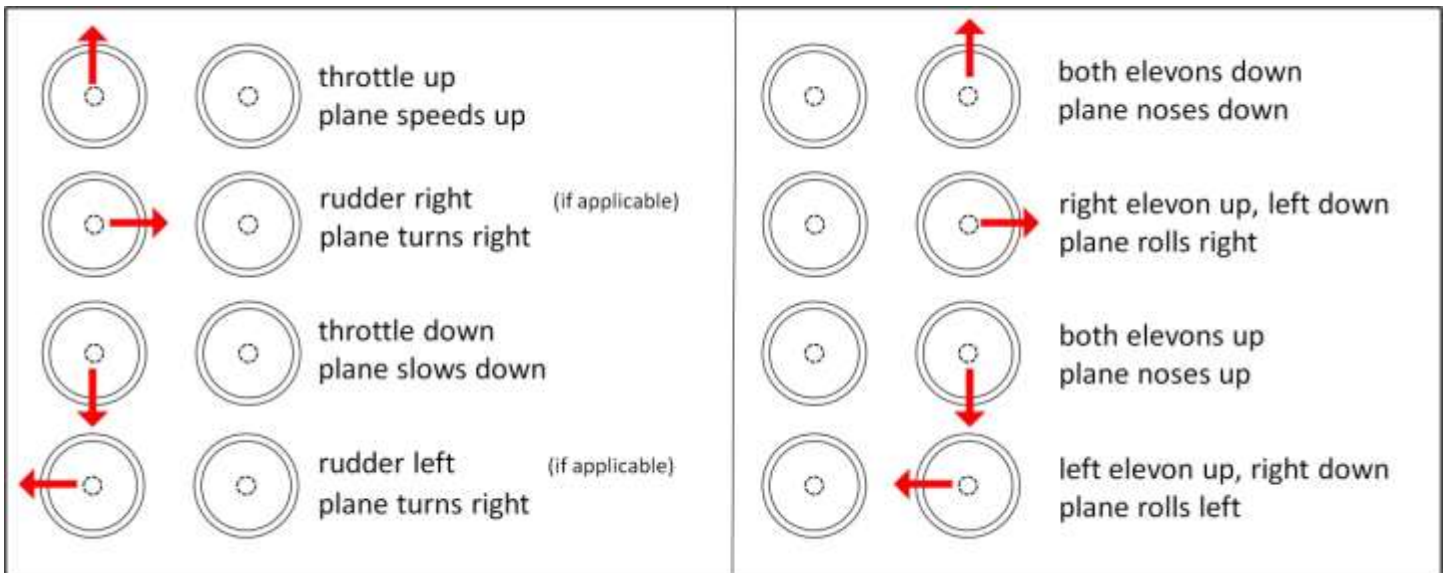

- g) Both elevons should be trimmed up 1/4" from center to set the "reflex" required by all flying wings and tailless planes.
- h) Set the wing on a flat surface, and hold a ruler vertically next to the trailing edge of each elevon. Use your tx to set the throw (range of movement) on the elevons to 3/8" (1cm) up and 3/8" down. Make sure your stick movement translates to the proper up/down on your elevons.
- i) If the elevons move too much move the pushrod closer to the center of the servo arm and move the pushrod to the tip of the horn on the elevon. This not only will decrease throws but increase leverage and make the servo forces stronger.
- j) If you still have too much movement, turn down the throws in the programming on the transmitter to get the throws in the right range.
- k) Most problems we see are: CG is wrong, too much throw in the elevons, plane is too heavy and pilot inexperienced.

A fix for the Spektrum DX6i radio mixing problems is available on our web site under Transmitters & Receivers.